

OPERATION MANUAL

HAND HELD REFRACTOMETER FOR ANTIFREEZE

AND BATTERY FLUID AND DEF

PARTS DIAGRAM

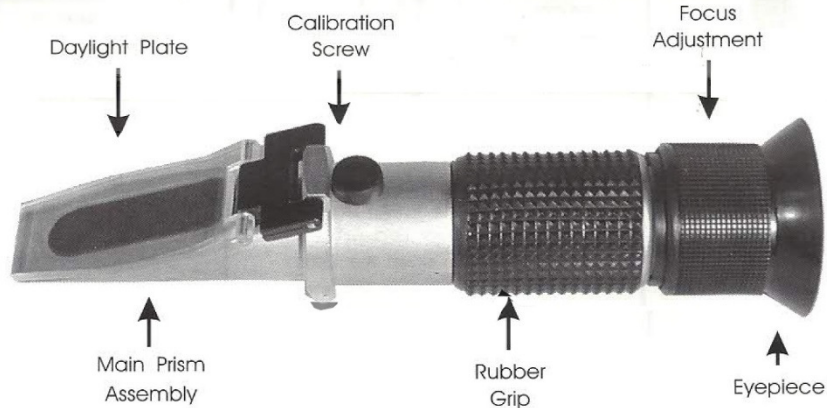

CALIBRATION PROCEDURE

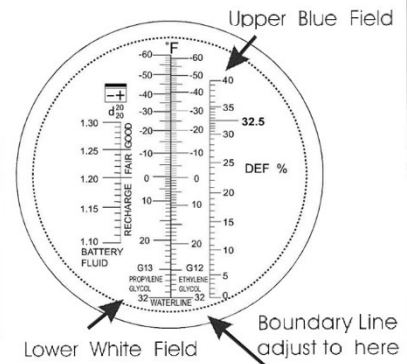
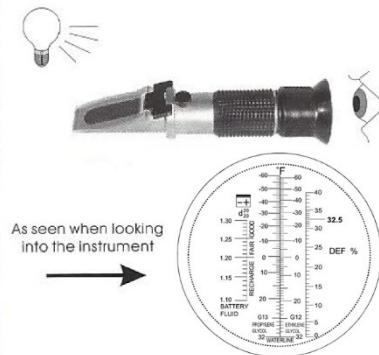
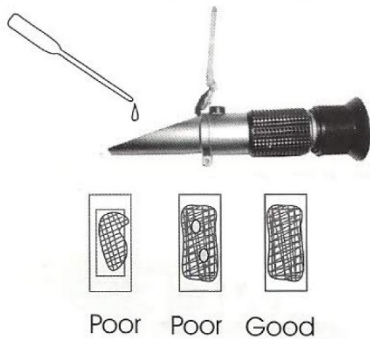

- 1) Open daylight plate, and place 2-3 drops of distilled water on the main prism. Close the daylight plate so the water spreads across the entire surface of the prism without air bubbles or dry spots. Allow the sample to rest on the prism for approximately 30 seconds before going to step #2. (This allows the sample to adjust to The ambient temperature of The refractometer)
- 2) Hold daylight plate in the direction of a light source and look into the eyepiece. You will see a circular field with graduations down the center (you may have to locus the eyepiece to see the graduations clearly). The upper portion of the field should be blue, while the lower portion should be white.
- 3) While looking into the eyepiece, turn the Calibration Screw until the boundary between the upper blue field and the lower white field meet exactly on 0°C. Once complete, the instrument is calibrated for your current ambient room temperature. When working temperature of the room or environment (not the sample) changes by more than 2C, we recommend recalibrating to maintain accuracy.

BASIC OPERATION

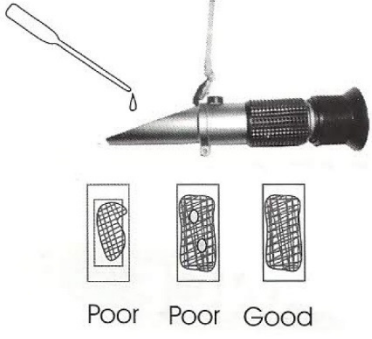
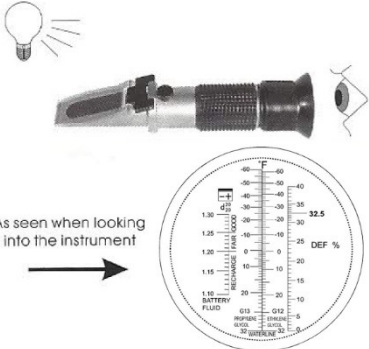
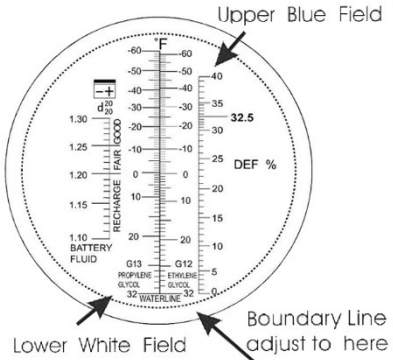
 <p>Poor Poor Good</p>	 <p>As seen when looking into the instrument</p>	
<p>1) Operation is done in essentially the same manner as calibration. Open daylight plate, and place 2-3 drops of the Liquid sample on the main prism. Close the daylight plate so the sample spreads across The entire surface of the prism without air bubbles or dry spots, Allow the sample to rest on the prism for approximately 30 seconds before going to step #2. (this allows the sample to adjust to the ambient temperature of the refractometer)</p>	<p>2) Hold daylight plate in the direction of a light source and look into the eyepiece. You will see a circular field with graduations down the center (you may have to focus the eyepiece to clearly see the graduations). The upper portion of the field should be blue, while the lower portion should be white.</p>	<p>3) Take the reading where the boundary line of blue and white cross the graduated scale. Clean the prism carefully using a damp soft cloth. Do NOT immerse in water. Read warnings below carefully before use.</p>

WARNINGS - MAINTENANCE

- 1) Accurate measurement depends on careful calibration, Follow the instructions above closely. Note: Shifts in ambient room temperature will necessitate recalibration and the sample must be allowed ample time to adjust to the temperature of the prism prior to measurement. The prism and sample MUST be at the same temperature for accurate results.
- 2) Do not expose the instrument to damp working conditions, and do not immerse the Instrument In water. If the instrument becomes foggy. Water has entered the body. Call a qualified service technician or contact your dealer.
- 3) Clean the instrument between each measurement using a soft damp cloth. **Failure** to clean the prism on a regular basis will lead to inaccurate results and damage to the prism's coating.
- 4) Do NOT measure abrasive or corrosive chemicals with this instrument. They can damage the prism's coating.
- 5) This is an optical instrument. It requires careful handling and storage. Failure to do so can result in damage to the optical components and its basic structure. With care, this instrument will provide years of reliable service.